

\\documentacion\trabajos\ANACAO36_BELATE_ALMANDOZ\vigentes\02_Estudio_de_Alternativas\Planos\06_ALTERNATIVA_SELECCIONADA\06_08_01_04_Tuneles_Belate_Sostenimientos.dwg, 05/02/2015 10:22:01, gloria

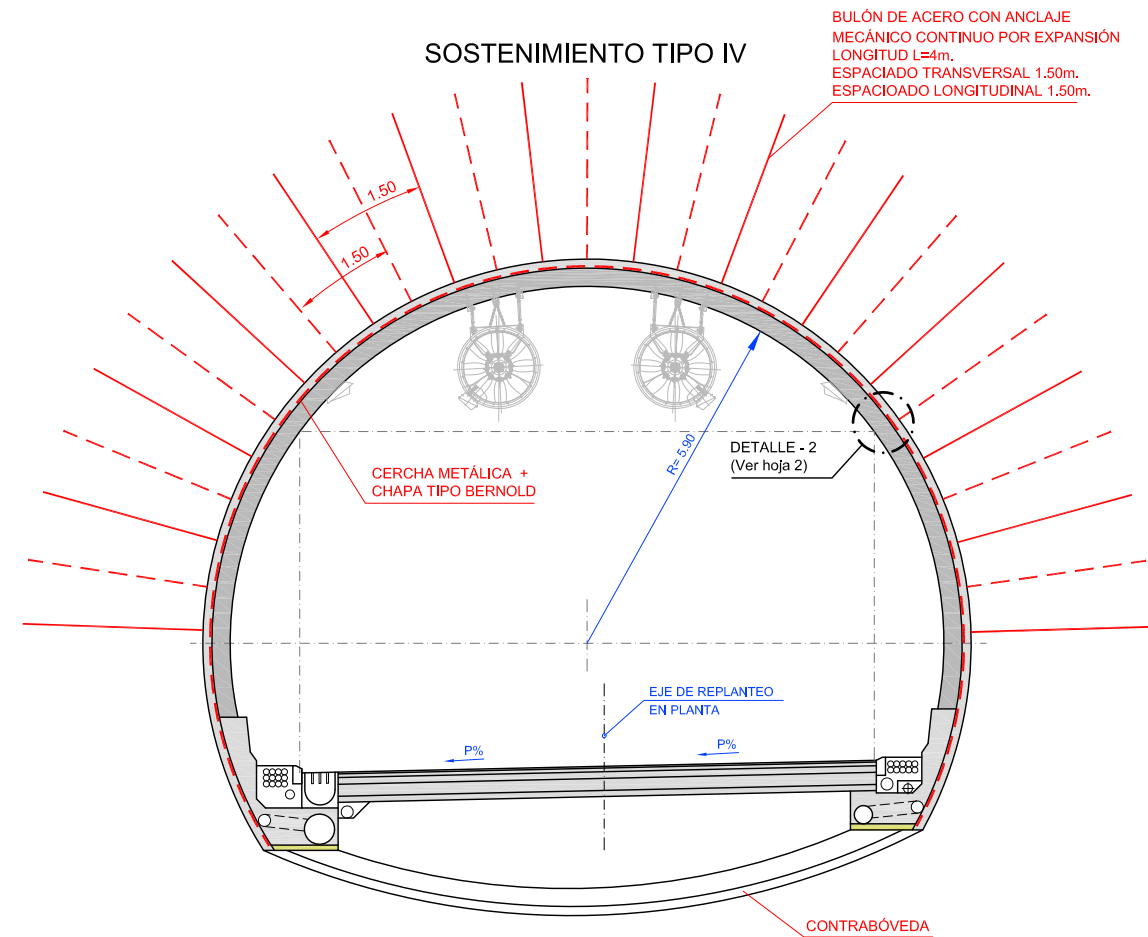

\\documentacion\trabajos\ANACA036_BELATE_ALMANDOZ\vigentes\02_Estudio_de_Alternativas\Planos\06_ALTERNATIVA_SELECCIONADA\06_08_01_Belate\TBA_06_08_01_04_Tuneles_Belate_Sostenimientos.dwg, 05/02/2015 10:23:02, gloria

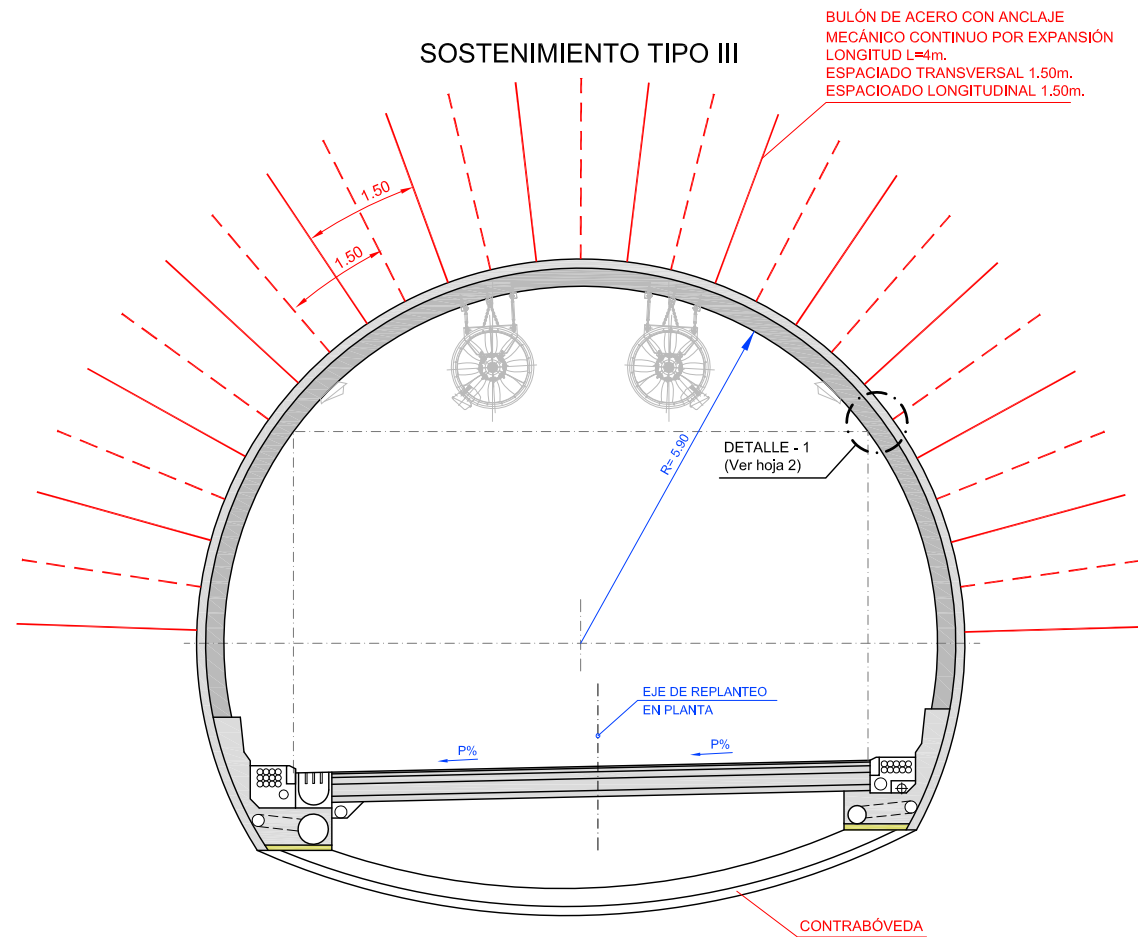
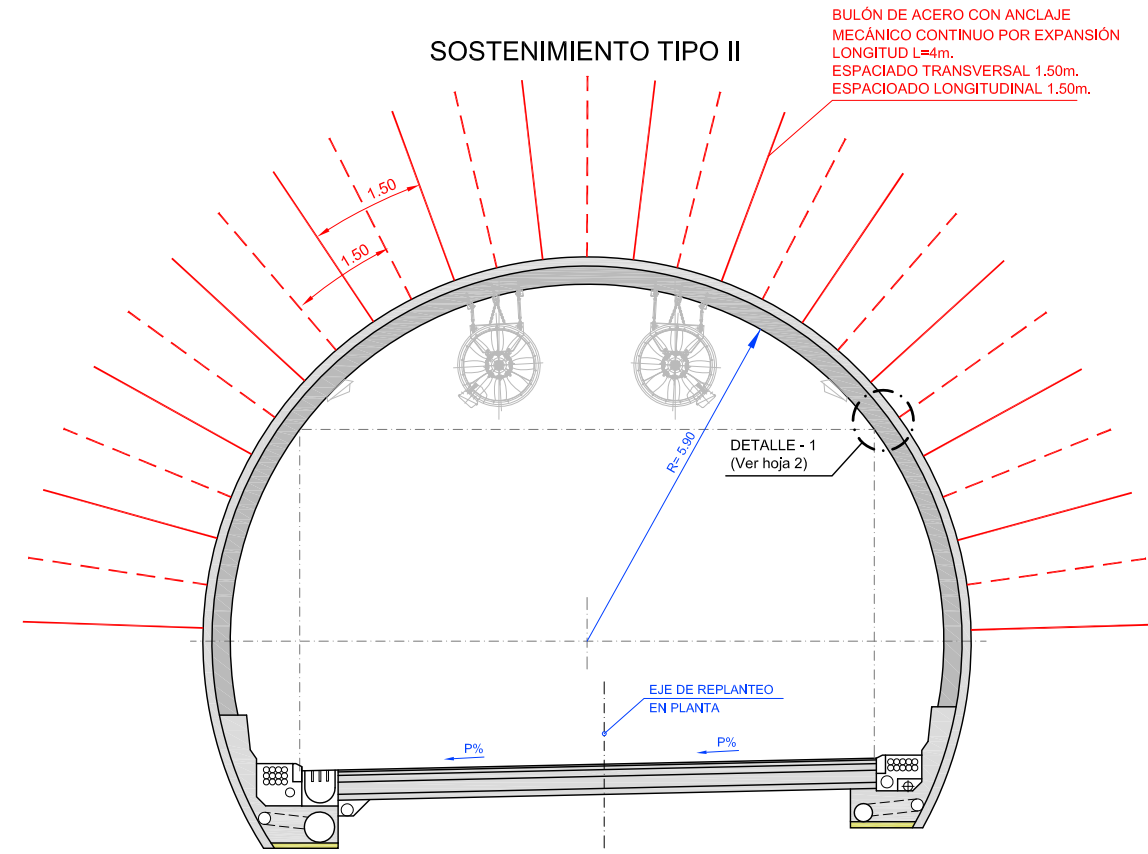
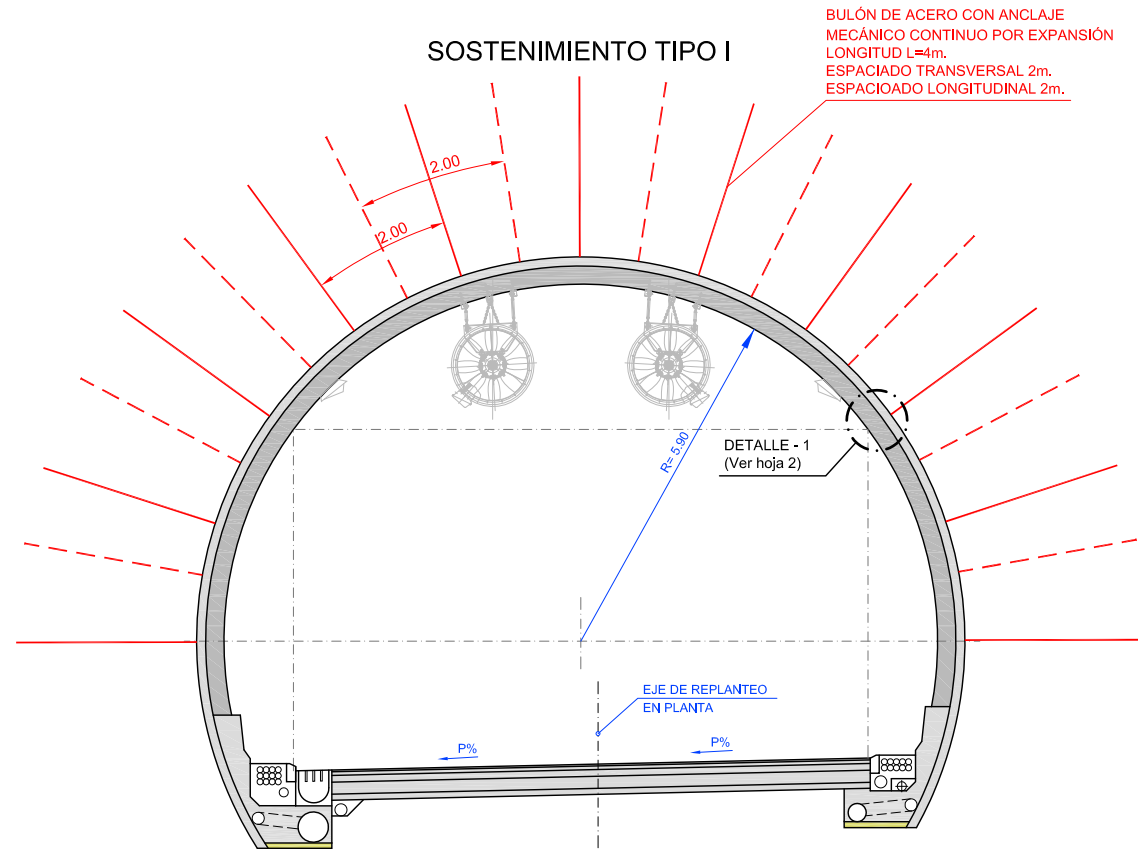